



PIASTRA GIREVOLE SWIVEL PLATE



▼ P/N: 9PG0066010V01

RENAULT Master

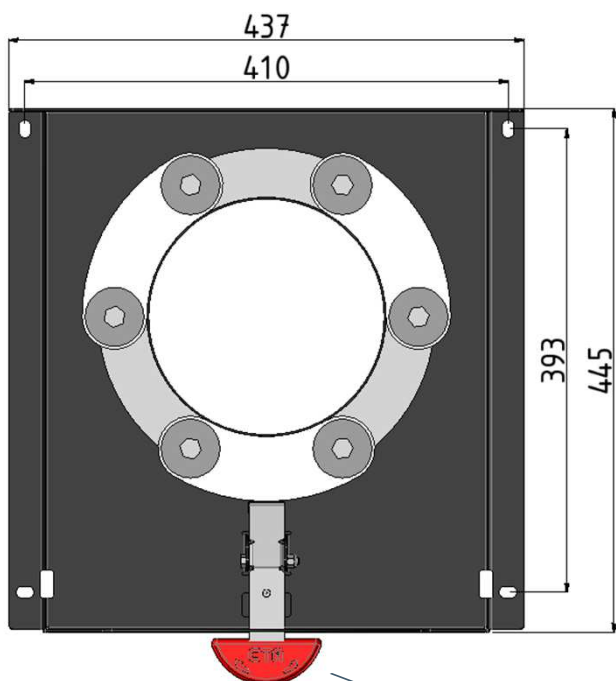

Grazie allo spessore ridotto, la piastra CTA rientra nel nuovo regolamento GSR2
Piastra girevole per sedile originale standard compatibile con modelli specificati. Design compatto e resistente, rotazione fluida, peso contenuto. Versione universale DX – SX.
Non è garantita la compatibilità per eventuali opt come sedili ammortizzati, sedili elettrici, etc.

Thanks to its reduced thickness, the CTA swivel plate complies with the new GSR2 regulation. Swivel plate for standard original seats, compatible with specified vehicle models. Compact and durable design, smooth rotation, and lightweight construction. Universal version for both left-hand (LH) and right-hand (RH) side installation. Compatibility is not guaranteed for optional features such as suspension seats, electric seats, etc., is not guaranteed.

Leva di sgancio
Release lever

DATI TECNICI/Technical Datasheet

Dimensioni/Dimension	437x444x25mm
Peso/Weight	6,9 kg
Materiale/Materials	Acciaio/Steel
Trattamento/Treatment	Verniciato/Painted
Colore/Colours	Nero/Black
R14-R17	RENAULT Master IV from 2023 – YTD

NOTA: per veicoli elettrici/ibridi con batterie sotto i sedili, le piastre girevoli non sono compatibili.

NOTE: for electrical/hybrid vehicles with batteries under the seats, the swivel plates are not compatibles

Prima dell'installazione verificare eventuali interferenze che impediscono il corretto funzionamento del sistema, eventuali modifiche rimangono a carico dell'allestitore.

Before installation, check for any interferences that prevent the correct functioning of the system, any modifications are the responsibility of the bodybuilder.

Rev. 00
06/11/2025



CTA S.R.L.

Via Nicaragua 4 • 00071 Pomezia (RM) Italy • Tel. - Fax 06.91601096

www.cta-europe.com

info@cta-europe.com